

MedTech Innovation and Training Center

Accelerating the Future of Healthcare Technology

Project Context: TKP2021-NKTA-36 – Development and
Evaluation of Innovative and Digital Health Industry Technologies.

A Bridge Between Theory and Clinical Reality

- Operated jointly by the University Research and Innovation Center (EKIK) and the John von Neumann Faculty of Informatics.
- Located at the Zsámbék Science and Innovation Park.

Core Mission:

To provide an internationally competitive innovation ecosystem for the development, validation, and market preparation of medical prototypes.

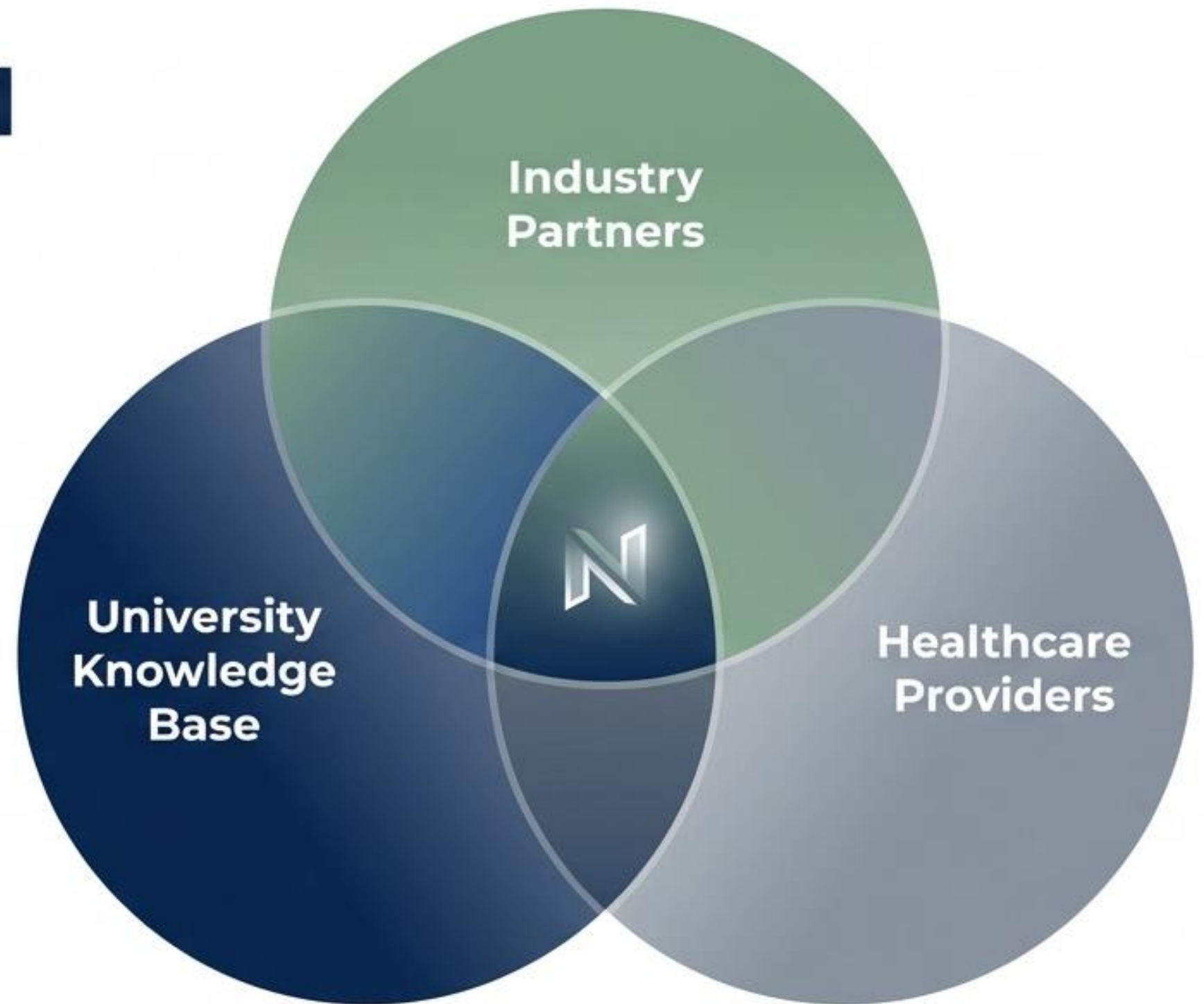

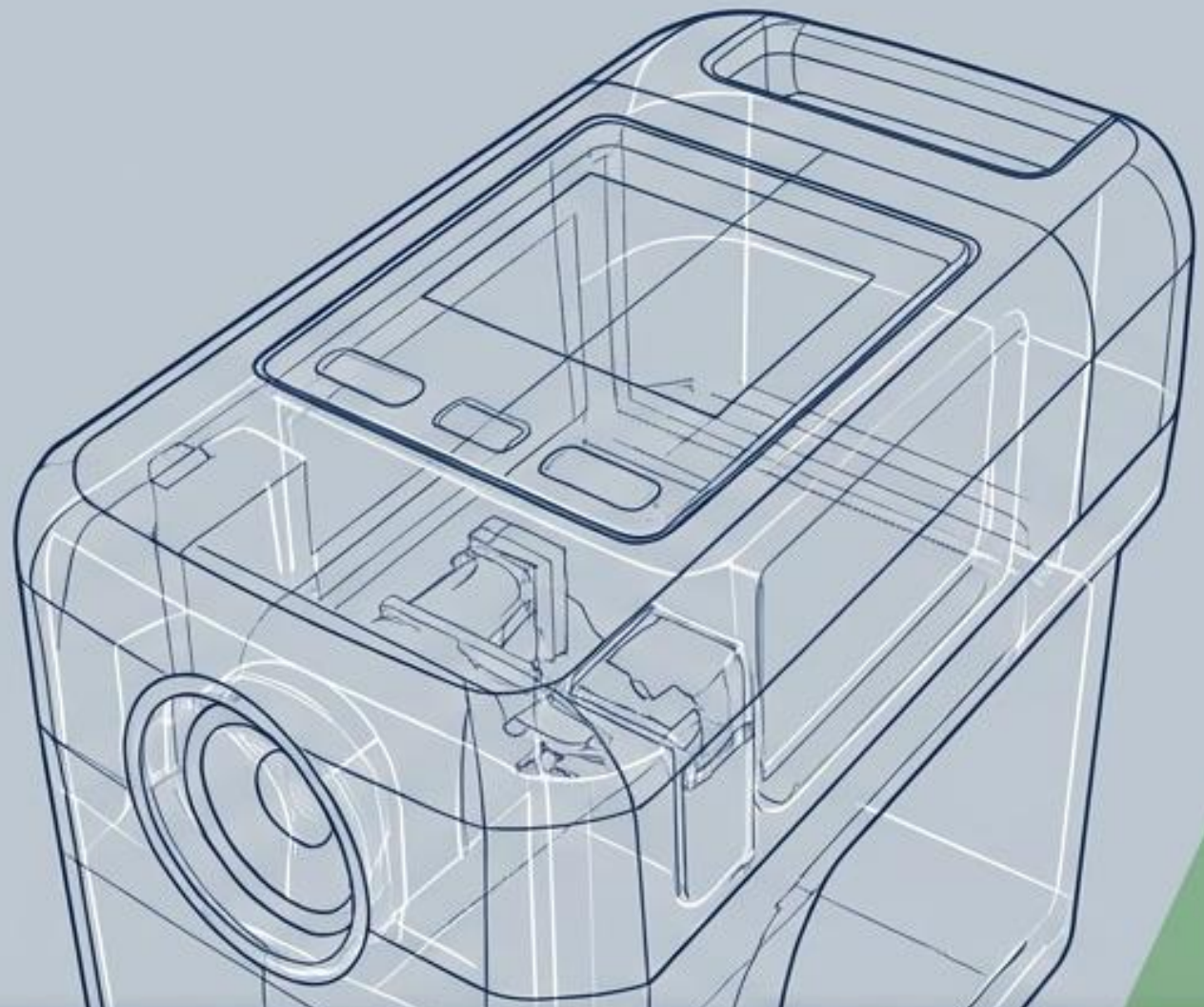

Workflow-Based Clinical Simulation

We do not test in a vacuum. We test in a fully modeled modern hospital environment.

- Real clinical workflow-based simulation.
- Complete device validation in a true-to-life environment.
- Comprehensive interoperability testing.
- Advanced educational and training programs.

The Digital Backbone: Integrated Health IT System (HIS)

Modeling complete institutional data management, patient pathway management, and clinical administration. Ready for integration with international HIS platforms.

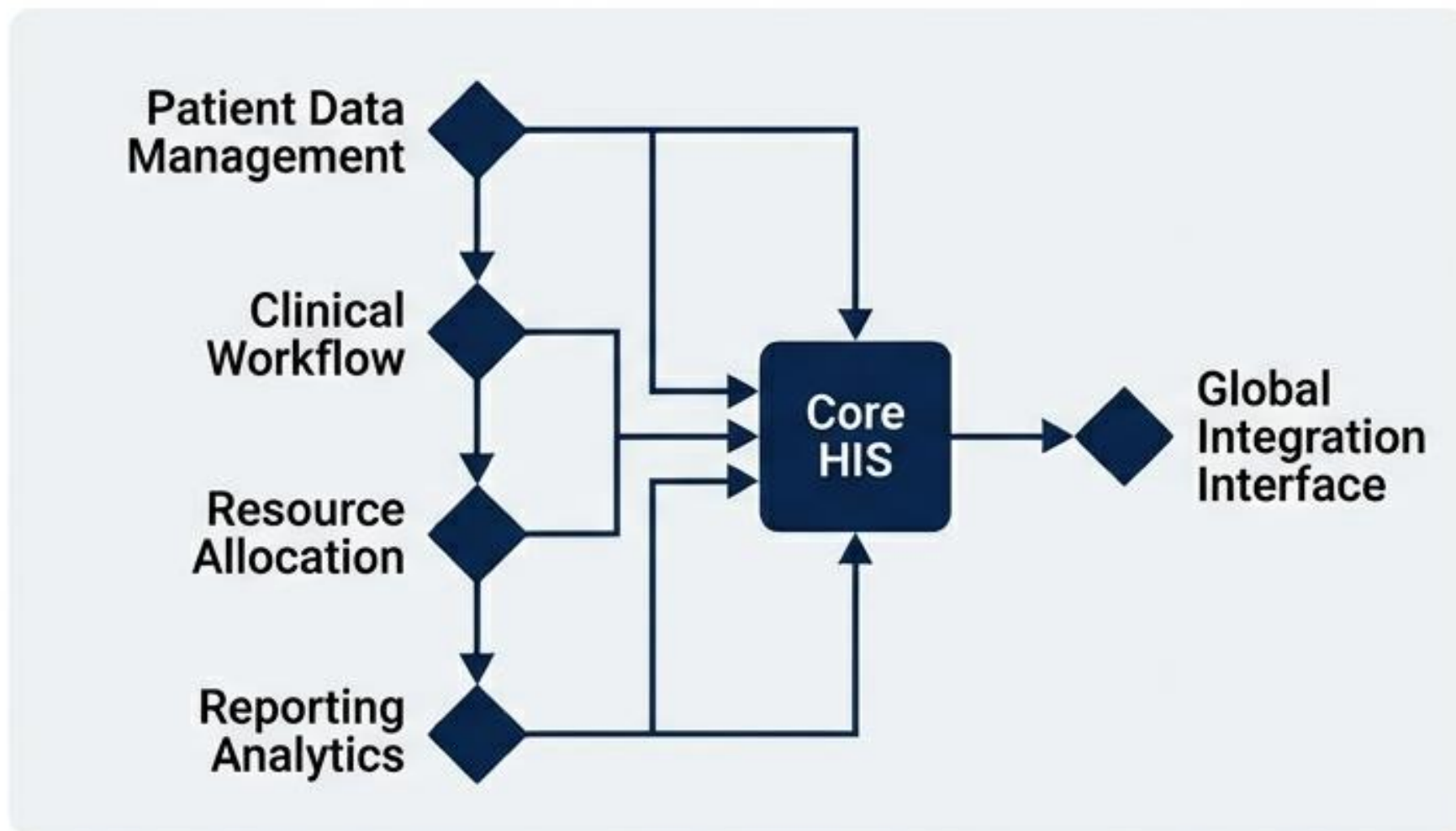

NEAK: Financing and reporting process modeling.



EESZT: National digital healthcare infrastructure connection.



HL7: Standardized healthcare data connections.



DICOM: Advanced image processing interfaces.

The Operating Room (OR) Environment

A full surgical theater designed for validating robotics, imaging systems, surgical tools, and operative workflows.

Adjustable Surgical Table ○

Ceiling-Mounted Surgical Light System ○

Integrated Camera & Suction Systems ○

Electrosurgical Unit (Cautery) ○

Anesthesia and Respiratory Support ○



Intensive Care Unit (ICU) Simulation

Modeled for the specialized care of critically ill patients, enabling the precise validation of life-support and intensive therapy technologies.

- ✓ • Advanced Simulator Mannequin for critical care training.
- ✓ • Multiparameter Patient Monitors and Data Concentrators.
- ✓ • High-end Ventilators and Infusion Pumps.
- ✓ • Field-ready hospital bed systems.



Paediatric Intensive Care Unit (PICU)

A dedicated environment focused on neonatal and infant care development, allowing prototype evaluation in highly sensitive clinical scenarios.

- ✓ Advanced Incubator Stations.
- ✓ Phototherapy (Blue Light) Systems.
 - Specialized Infant Monitoring Systems.
 - Precision Temperature Control & Respiratory Support.



Rapid Prototyping: The FabLab

Move from concept to physical iteration in hours. The dedicated FabLab station ensures that MedTech hardware development can happen iteratively on-site.

- Bank of professional-grade 3D printers.
- Immediate hardware iteration based on clinical simulation feedback.
- Bridging the gap between software design and physical implementation.



Comprehensive Validation Arsenal



Physiological Monitoring

Wearable sensors (HR, GSR),
Mobile & Single-channel EKGs,
Multiparameter monitors.



Neurological & Specialized

EEG Systems (by g.tec),
Diabetes-related medical
devices.



Therapeutic Delivery

Advanced infusion and syringe
pumps, Electrosurgical
equipment.



Data Management

Data concentrator systems,
Interoperable IT interfaces.

Uncompromising Quality & Certification

We provide an accredited validation environment to prepare your technology for global markets.



ISO 9001

Quality Management
Systems



MSZ EN ISO 13485:2016

Medical Device Quality
Management



MDR/IVDR

European compliance
validation background



ISO/IEC 42001:2023

Artificial Intelligence
Management System



Educating the Next Generation

Training professionals on tomorrow's technology, today.

- Specialized postgraduate training.
- Targeted industry workshops.
- Device usage and validation training.
- Multidisciplinary project integration for real-world problem solving.

Accelerating Time-to-Market

Direct support for industry developers, health IT projects, and MedTech manufacturers.



- Accelerated industrial prototype and product development.
- Clinical engineering and usability testing.
- Technical validation environments required for CE compliance.
- Strategic support for grant consortiums, startups, and spin-offs.

Expert Leadership

Backed by the deep academic and industrial competencies of Óbuda University.

Prof. Dr. György Eigner

Dean of the John von Neumann Faculty of Informatics &
Head of the Research Center



Clinical Engineers & Health IT Leaders

 Clinical Engineers & Health IT Leaders

 Clinical Engineers & Health IT Leaders



Quality Assurance & MDR/IVDR Certification Experts

 Quality Assurance & MDR/IVDR Certification Experts

 Quality Assurance & MDR/IVDR Certification Experts



R&D Project Managers

 Project Assign and Management Competential

 R&D Project Managers

Join Our Innovation Ecosystem

We invite health industry developers, medical device manufacturers, and health IT innovators to leverage this internationally unique infrastructure.

-  Location: Óbuda University, Bécsi út 96/b, Budapest, Hungary
-  Contact: Péter Árvai, Laboratory Engineer
-  Email: arvai.peter@uni-obuda.hu
-  Phone: +36-30-710-8505
-  Portal & Quotations: medtech.uni-obuda.hu

Strategic Partners & Acknowledgments

The structural and equipment implementation of the MedTech Laboratory was supported by:

Rudolf Kálmán Foundation for Óbuda University

Ministry of Finance

National Directorate General for Hospitals

MediCluster

MEDICOR Elektronika Zrt.

Hospitaly Kft.

Endoplus Kft.



ÓBUDA UNIVERSITY
EKIK



AZ NKFI ALAPBÓL
MEGVALÓSULÓ
PROJEKT